

INDUSTRY GUIDELINES & RECOMMENDATIONS FOR

PART II OF II

UNDERLAYMENTS

BY KARL SCHAACK, RRC, PE

Currently, there are a multitude of material types, compositions, and installation techniques available for underlayments for steep-slope roof assemblies. This is the second of a two-part paper on underlayments and is to provide a general summary of the many different requirements and/or guidelines that have been established by the various code-enforcing bodies and industry associations for underlayments. The various standards published by ASTM related to underlayments are outlined in Part I, published in the February 2006 issue of *Interface*. The following is a summary or compilation of the various guidelines, recommendations, or requirements for underlayments published by their respective entities.

National Roofing Contractors Association (NRCA)

Based on information presented in the fifth edition of the *Roofing & Waterproofing Manual*, the following outlines the guidelines developed by NRCA for underlayments.

Shingle:

- A. Asphalt self-sealing strip shingles, laminated asphalt shingles, and individual lock-down shingles may be applied on roof decks with slopes of four inches per foot or more when a minimum of one layer of No. 15 asphalt-saturated (non-perforated) felt is applied horizontally to serve as the underlayment.
- B. Asphalt self-sealing strip shingles with tabs may be applied on roof decks with slopes of three inches per

foot or more when a minimum of two layers of No. 15 asphalt-saturated (non-perforated) felt are applied horizontally to serve as the underlayment.

- C. Asphalt self-sealing strip shingles with tabs may be applied on roof decks with slopes of 2-1/2 inches per foot or more when a minimum of two layers of No. 15 asphalt-saturated felt are set in hot asphalt or mastic to serve as the underlayment.
- D. On roof decks with slopes less than four inches per foot and (regardless of the slope) in locations where the January mean temperature is 30 degrees Fahrenheit or less, two plies of No. 15 felt or one ply of No. 50 felt, set in hot asphalt or mastic or an

adhered bitumen membrane underlayment should be applied starting from the eaves to a point 24 inches inside the inside wall line to the building to serve as an ice shield.

Tile Underlayment:

- A. Roll (mission) tile or flat tile may be applied on roof decks with slopes of four inches per foot or more when a minimum of one layer of 43-pound cap sheet underlayment is applied.
- B. Any style of clay tile may be applied on roof decks with slopes less than four inches per foot when a minimum of two layers of No. 40 asphalt-saturated (non-perforated) felt is set in hot asphalt or mastic to serve as the underlayment.

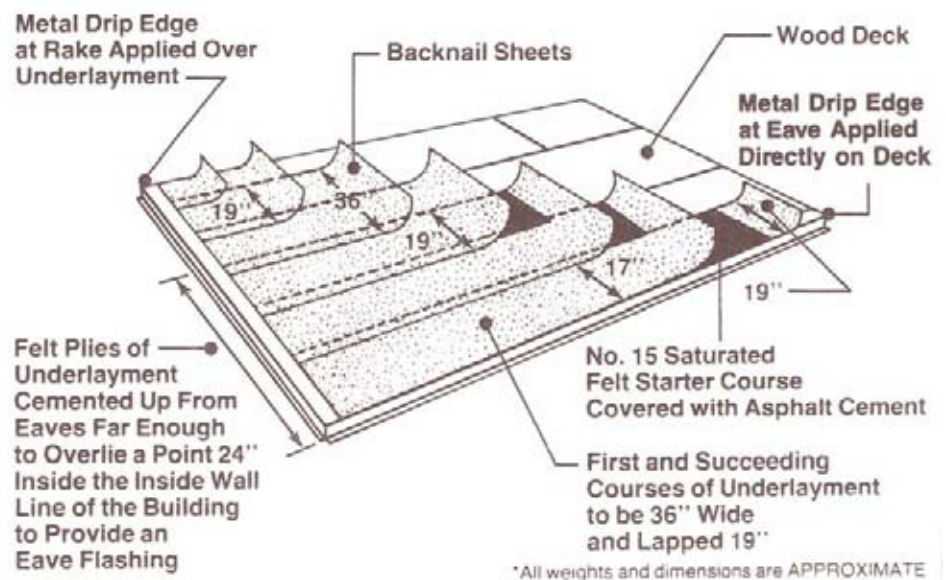

NRCA double layer of felt underlayment. Source: NRCA Roofing and Waterproofing Manual.

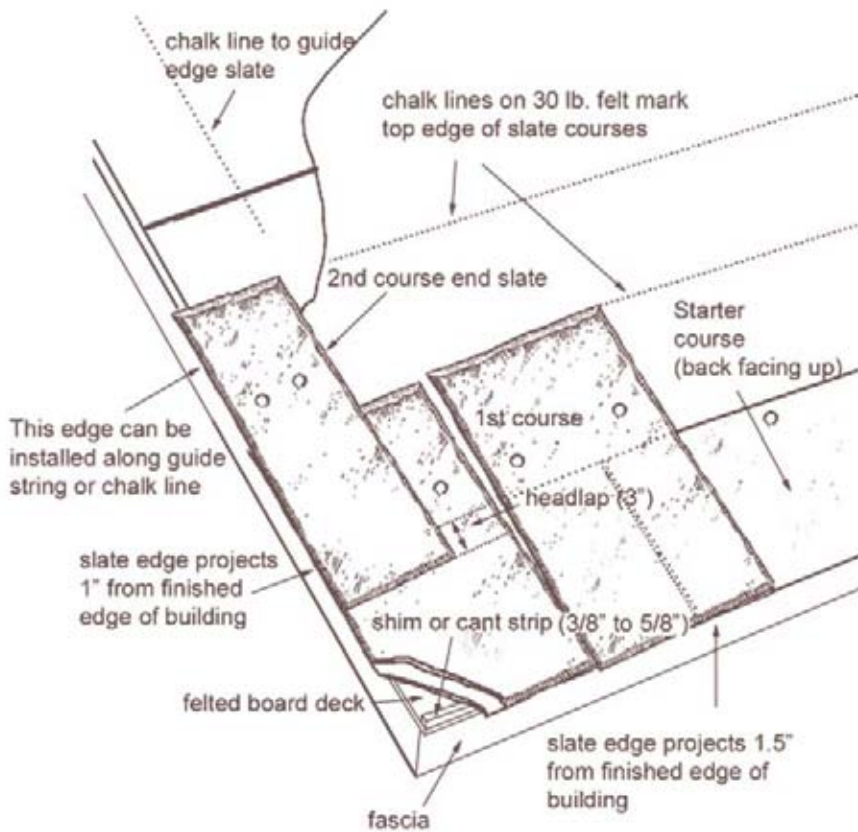

Typical underlayment installation with slate. Source: Slate Roof Central, "How to Install a Traditional Slate Roof."

- C. Regardless of slope, in locations where the January mean temperature is less than 30 degrees Fahrenheit, refer to the application procedures outlined in the cold-weather application section.

Cold Weather Clay Tile Roofing:

- A. A minimum of one layer of 40-pound coated felt applied horizontally with a minimum four-inch headlap and six-inch side lap is required. On slopes below four inches in 12, a functional, built-up roof, modified bitumen roof, or an ice-and-water-shield self-adhering bitumen membrane underlayment system is required. In addition to the 40-pound underlayment, on eaves and barges (rakes), regardless of the slope, the following is required, starting from the eave and barge to a point 36 inches beyond the inside wall line of the structure to serve as an ice shield: one layer of 40-pound coated felt set in roofer's mastic, cold-process adhesive, or one layer of self-adhering ice-and-water-shield bitumen membrane.

Slate:

- Felts for use in slate roofing should be unperforated, asphalt-saturated felts, No. 30 or heavier.
- In locations where the January mean temperature is 30 degrees Fahrenheit or lower, two plies of No. 15 felt or one ply of No. 50 felt, set in hot asphalt or mastic, or an adhered bitumen membrane should be applied as the underlayment, starting from the eaves to a point 24 inches inside the inside wall line of the building to serve as an ice shield.

Asphalt Roofing Manufacturers Association (ARMA)

In the *Residential/Steep Roofing Manual* and published technical bulletins, ARMA suggests that shingle underlayment products shall be asphalt-saturated, non-perforated sheets complying with ASTM D 226 or D 4869.

Copper Development Association (CDA)

The CDA provides general guidelines for underlayments in the *Copper in Architecture Handbook*. This information is presented in the paragraph 4.2.B, "Surface Preparation,"

in the subsection "Roofing Systems" under the "Details" section. The information is as follows:

"The entire surface should be covered with an approved underlayment secured with copper nails and washers. The underlayment, which is often saturated roofing felt, acts as a cushion, as well as providing temporary weather protection for the roof deck. A sheet of building paper must be applied over the felt. Because copper has a tendency to retain heat, elevated temperatures can cause asphalt in the underlayment to bond the copper to the roof deck. This inhibits the movement of the copper roof and can result in premature fatigue. The building paper acts as a slip sheet to prevent such bonding."

Cedar Shake & Shingle Bureau (CSSB)

The Cedar Shake and Shingle Bureau outlines requirements for underlayments in its technical installation manual. CSSB recommends that underlayment or interlayment consist of No. 30 asphalt-saturate felt installed between alternating courses of wood shingles or shakes.

Canadian Asphalt Shingle Manufacturer's Association (CASMA)

The CASMA, as stated in *Technical Bulletin No. 3 1992-09-01*, recommends that the underlayment material should meet at least one of the following industry standards:

- 1) CSA 123.3-M – No.15/ASTM D 226 Type 1 (No. 15 felt); or
- 2) CAN 2-51.32 – Breather Type Sheathing Paper.

Metal Building Manufacturers' Association (MBMA)

The MBMA outlines recommendations for underlayments in its handbook. Accordingly, it states that standard asphalt-saturated, organic felt, ASTM D 226 – either a single layer of #30, or two layers of #15 – are deemed acceptable. Perforated felts should not be used. The underlayment should be installed horizontally, parallel to the eave, lapped two inches along sides and six inches at ends, not occurring concurrently in adjacent tiers. One-inch diameter synthetic cap nails are recommended for securing the underlayment.

MBMA recommends using precaution when utilizing modified bituminous underlayments under metal panels due to the

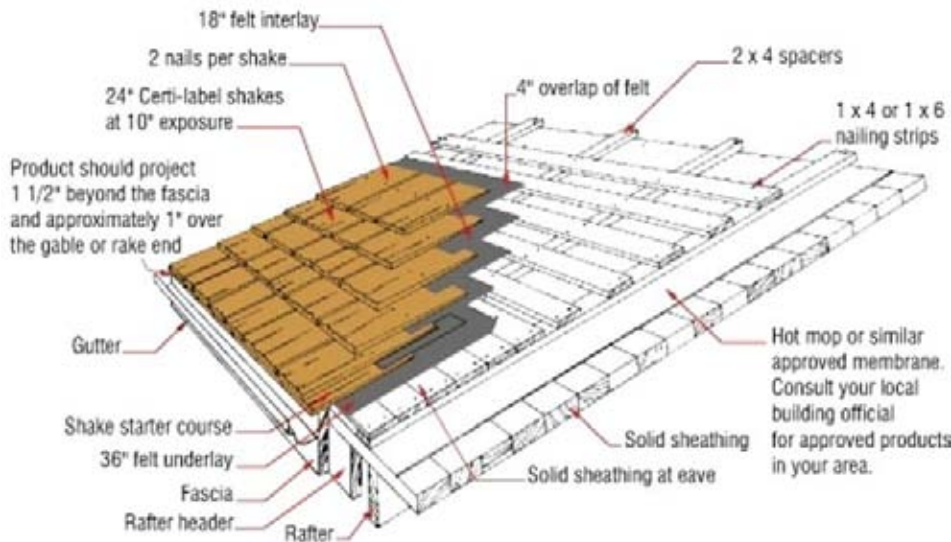

Diagram of interlayment in wood shake construction. Source: Cedar Shake & Shingle Bureau, *New Roof Construction Manual*, January 2006, Figure 4, Page 4, Certi-label Shake™ application.

high temperatures (i.e., 200 degrees F) that could be reached under certain colors or types of metal panels and the low flow rate temperature of these products. MBMA also cautions that self-adhered modified bitumen sheets may lose tackiness when applied directly to OSB sheathing due to a wax finish that is applied to the surface of OSB during the manufacturing process. Another precaution identified by MBMA is using underlayments with granule surfacing under metal panels, due to the potential of abrading the underside of the metal panel as the panel undergoes movement from thermal cycling. This abrasion of the underside of the metal panel could lead to corrosion and subsequent premature failure of the panel.

American Plywood Association (APA)

The APA does not identify a specific material for underlayment, but rather outlines the installation procedures. The APA does provide recommendations for ice dam considerations. For prevention of saturation of the plywood sheathing from ice dams, APA recommends an initial felt ply, minimum No. 30 asphalt-saturated felt, fully-adhered to the plywood sheathing with vertical-grade asphalt cement, starting at the eave and extending 24 to 36 inches inside the exterior wall line. After this “starter ply” is installed, a two-ply felt underlayment is then attached to the sheathing starting at the eave. APA also suggests the use of a self-adhering underlayment in lieu of the cemented felt ply. This type of underlayment application is also recommended for

use in low-slope roofs or in areas of wind-driven rain or snow.

Federal Emergency Management Association (FEMA)

FEMA has provided recommended practices for use of roofing underlayment as an enhanced secondary water barrier in hurricane-prone areas (both coastal and inland)

as published in its *Recovery Advisory No. 1 – Roof Underlayment for Asphalt Single Roofs*, dated September 2004. The bulletin outlines three options in decreasing resistance to long-term weather exposure following the loss of the roof covering.

Option 1 provides the greatest reliability for long-term exposure and is advocated in heavily populated areas where the design wind speed is equal to or greater than 120 mph (three-second peak gusts). This scenario is as follows:

- Install self-adhering modified bitumen tape (four inches wide minimum) over sheathing joints and around penetrations and roll tape;
- Apply a single layer of ASTM D 226 Type II (#30) felt secured six inches o.c. along the laps and 12 inches o.c. along two rows in the field of the sheet between the side laps;
- Apply a single layer of self-adhering modified bitumen complying with ASTM D 1970 over the #30 felt throughout the roof area; and then
- Seal the self-adhering sheet at penetrations with strips of the modified bitumen (roof tape) or asphalt roof cement.

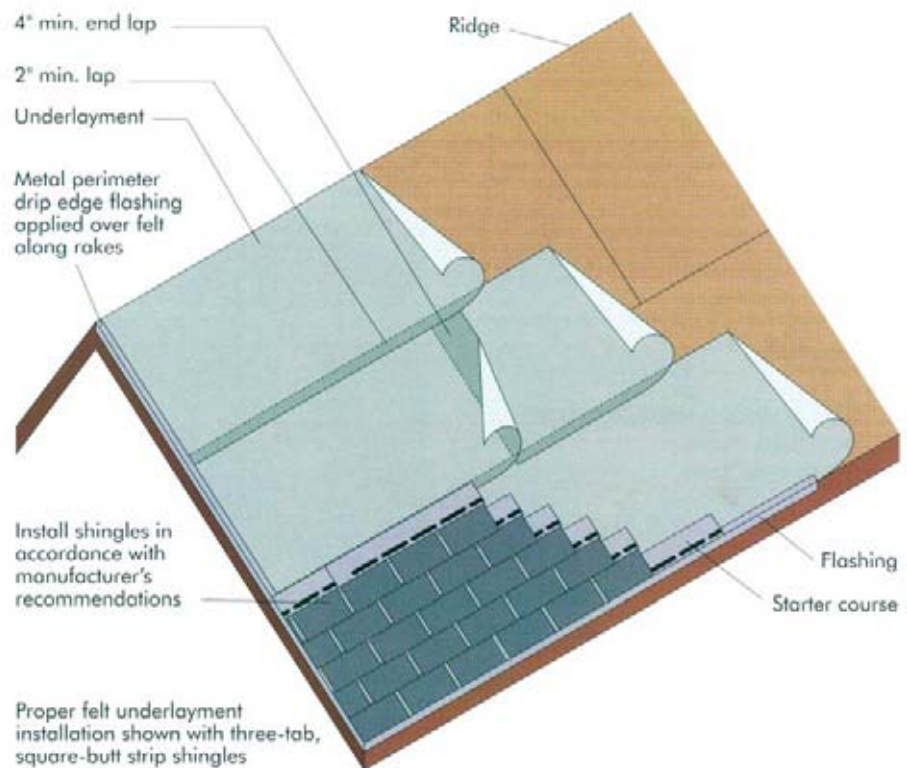

Typical single layer of felt underlayment installation for steep-slope roofing. Courtesy APA – the Engineered Wood Association, from its publication, *Build a Better Home*.

Option 2 includes the taped sheathing joints, and then two layers of ASTM D 226 Type I (#15) felt, secured with offset side laps.

Option 3 includes the taped sheathing joints, and then tacking in place a single layer of #15 felt.

Dade County/South Florida

The 1994 edition of the South Florida Building Code identifies the requirements for underlayments in Chapter 34. The definition of an underlayment is “one or more water-shedding layers applied to a sloped roof prior to the application of a Prepared Roof Covering. The primary purpose of an underlayment is defined as a water-shedding layer to function in conjunction with a Prepared Roof Covering.”

The application and testing standards for Dade County are published in *Protocols*. The handbook is comprised of two volumes and is a compendium of protocols and application standards. Volume I is comprised of application standards and field test procedures, and Volume II is comprised of test methods for testing roofing components and roof system assemblies.

Test procedures for underlayment products are included in Volume I. Self-adhered and “nailed-on” underlayments for use in discontinuous roof systems shall be tested in compliance with Dade County Protocols PA 103, “Test Procedure for Self-Adhered Underlayments for Use in Discontinuous Roof Systems,” and PA 104, “Test Procedure for Nail-On Underlayments for Use in Discontinuous Roof Systems,” respectively. These protocols cover procedures for testing either self-adhering (PA 103) or mechanically-attached (PA 104), prefabricated, reinforced, polymer-modified bituminous, and solid thermoplastic sheet roofing materials intended for use as underlayments in discontinuous roof systems to assist in the waterproofing function in combination with a prepared roof covering. If the product has a granular surfacing on one side, the Granular Adhesion Test is required. These test procedures determine the following performance criteria for these products:

- Wind uplift resistance (90 psf),
- Thickness (60 mils minimum),
- Dimensional stability (material that exhibits shrinkage/wrinkling that compromises the lap seam or tears at fastener penetrations is considered failing),
- Tear resistance (3.5 lbf minimum),
- Breaking strength,

- Elongation,
- Water absorption (3% max),
- Low temperature flexibility (no cracking at -10 degrees F),
- UV resistance (material exhibiting peeling, chipping, cracking, flaking, pitting, or other detected damage under 5x magnification is considered failing),
- Accelerated aging (minimum 85% of original values),
- Cyclic elongation (material exhibiting cracking after testing is considered failing),
- Water vapor transmission (maximum 1.0 g/m² in 24 hours),
- Compound stability (material exhibiting flowing, dripping, or drop formation at less than 220 degrees F is considered failing),
- Puncture resistance (any material exhibiting puncture after testing is considered failing);
- Tile slippage resistance (material exhibiting tears or tile slippage is considered failing),
- Crack cycling resistance (material exhibiting cracking after testing is considered failing),
- Peel resistance (minimum 6.5 lbf/foot of width, aged value mini-

- mum 75% of original value), and
- Granular adhesion (maximum granule loss, 0.75 grams).

In Volume II of the handbook, three application standards outline the products and application choices for underlayments under tile. These standards are as follows:

- PA 118 95, System #2: Model Nail On Tile Specification, Including Approved Underlayment Assemblies And Standard Flashing Details;
- PA 119-95, System #1: Model Nail On Tile Specification, Including Approved Underlayment Assemblies And Anti-Ponding Flashing Details, and
- PA 120-95, System #3: Model Mortar Or Adhesive Set Tile Specification Including Approved Underlayment Assemblies.

The following products are listed in paragraph 2.02, Asphalt-saturated Roofing Underlayments:

- Organic anchor sheet, commonly called No. 30 or 30#, specifically ASTM Standard D 226, Type II for use in conjunction with an appropriate “cap sheet.”
- Organic saturated or ASTM D 2626,

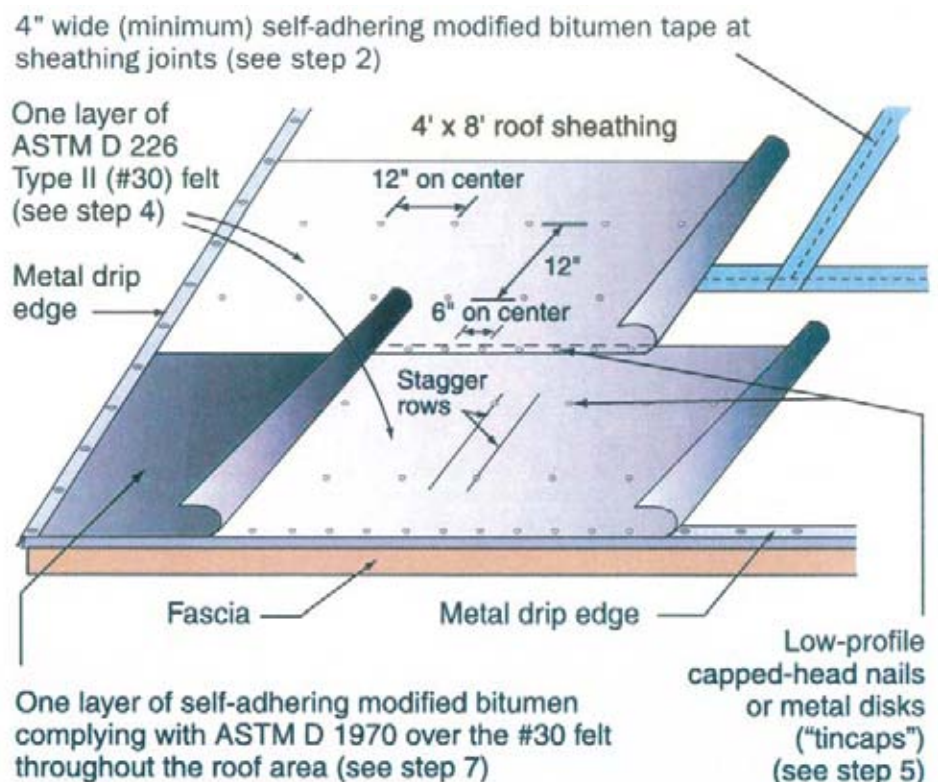

FEMA recommendations for underlayment in high wind areas (120 mph+). Source: FEMA Hurricane Recovery Advisory No. 1.

Type II asphalt saturated and coated base sheet for use in two-ply applications and as an anchor sheet.

- C. Mineral surface roll roofing felt, minimum 74# (commonly called 90#), specifically ASTM D 249 for use in two-ply hot mopped or cold applications as a cap sheet.
- D. Modified bitumen single-ply membrane in compliance with Dade County Protocol PA 104, and listed as a tile system underlayment in the Membrane Manufacturers' Product Control Approval.
- E. Self-adhered membrane in compliance with Dade County Protocol PA 103.
- F. Granular-surfaced, SBS-modified bitumen membrane, minimum 3.5 mm at the selvage edge, approved for use in the South Florida Building Code jurisdiction.

The following application scenarios are listed in paragraph 3.02 as approved underlayment compositions:

- A. Nail one layer of #30 and hot mop one layer of 90#.
- B. Nail one layer of #43 and hot mop one layer of 90#.
- C. Nail one layer of #30 and hot mop one layer of "Modified Bitumen Cap."
- D. Nail one layer of #43 and hot mop one layer of "Modified Bitumen Cap."
- E. Nail one layer of #30 and apply one layer of 90# in cold process adhesive.
- F. Nail one layer of #43 and apply one layer of 90# in cold process adhesive.
- G. Nail two plies of #30.
- H. Nail two plies of #43.
- I. Nail one ply of "anchor sheet" (#30 or #43) and one ply of self-adhered sheet.
- J. Nail two plies of #43 and seal end and side laps with asphalt or plastic roof cement.
- K. Alternative/product control approved method: Any product consisting of one or more water shedding layers having been tested in compliance with Product Control Approval guidelines in accordance with Dade County Protocol PA 100, "Test Procedure for Wind and Wind-driven Rain Resistance of Discontinuous Roof Systems."

as follows: "The attachment method for the nailed underlayment shall be fasteners spaced six inches on center at two-inch side laps and six-inch end laps, and two rows of fasteners, staggered, spaced 12 inches on center in the field of the sheet."

In Volume II, the application standard PA 133-95, "Standard Procedures for Installation of and Flashings For Metal Roof System Assemblies," outlines products and criteria for underlayments under metal roof assemblies installed over wood deck. As presented in Appendix A of the protocol, "The underlayment shall be an application of a #30 felt (ASTM D 226, Type II) or #43 coated base sheet (ASTM D 2626) attached in a grid pattern of 12 inches with 6-inch o.c. spacing at 6-inch side laps. Head laps shall be not less than 3 inches. The attachment grid pattern shall be decreased to 10 inches with 6-inch spacing at 6-inch laps on installations above 100 feet. Self-adhered underlayments may be substituted for the above underlayment, provided the membrane is installed in compliance with a Self-adhered Underlayment Product Control Approval."

National Tile Roof Manufacturer's Association (NTRMA)

Similar information for underlayments was also presented in the *Concrete and Clay Roof Tile Installation Manual*, First Edition (FRSA/NTRMA 07320/11-96) published in 1996 by the Florida Roofing Sheet Metal and Air Conditioner Contractors Association in conjunction with the Florida Chapter of the National Tile Roofing Manufacturers

Association (now RTI).

- A. #43 organic base nailed to deck.
- B. #74 organic cap sheet nailed to deck.
- C. #30 or #43 organic base nailed to deck, minimum #74 organic cap sheet in Type IV hot asphalt.
- D. #30 or #43 organic base nailed to deck, minimum 40-mil SBS modified cap sheet in cold-applied adhesive.
- E. #30 or #43 organic base nailed to deck, minimum #74 organic cap sheet with or without cold-applied adhesive.
- F. Approved nail-on, single-ply modified underlayment.
- G. #30 or #43 organic base nailed to deck, self-adhered membrane bonded to base ply.
- H. Approved, self-adhered underlayment applied direct to wood deck.
- I. Double layer #30.
- J. Double layer #43.
- K. Approved, double-layer underlayment system (proprietary).

Roof Tile Institute (RTI) and Western States Roofing Contractors Association (WSRCA)

The following information regarding underlayments is presented in the *Tile Manual* published by RTI and WSRCA and the *Design Criteria Installation Manual for Moderate Climate Regions Concrete/Clay Tile 1/1/0.* Underlayment as defined by RTI is "a water-shedding membrane installed over the roof sheathing, rafters, or trusses."

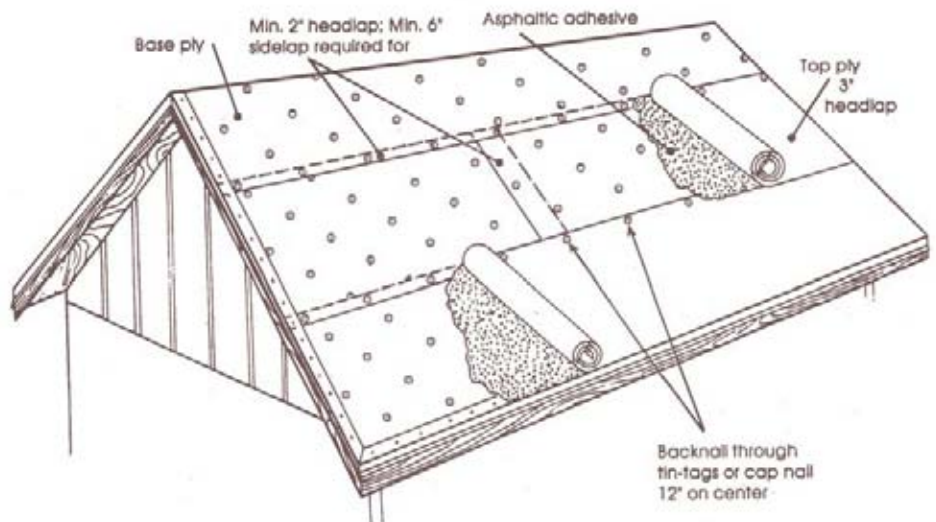

The protocol also identifies the requirement for attachment of the underlayment

Diagram of 2-ply, hot-mopped underlayment. Source: FRSA/NTRMA Concrete and Clay Roof Tile Installation Manual, First Edition.

A. One layer of minimum ASTM D 226, Type II (No. 30 felt), listed in a recognized code evaluation report, shall completely cover the decking and be lapped six inches vertically (end or side lap) and two inches horizontally (head lap). On roof slopes from 2-1/2:12 to below 3:12, an approved, built-up roof membrane assembly (three plies minimum applied per the building code requirements), applied in accordance with Table 1, or a single-ply roof membrane assembly or other underlayment system

approved by the local building official, is first installed.

B. Where roof slopes fall between 3:12 and under 4:12, underlayment may be as described in the previous paragraph, or:

- A single-layer, type 90 granular-surfaced, asphalt roll roofing; or
- Two layers of ASTM D 226, Type II (No. 30 felt), installed shingle fashion; or
- Single-ply system installed per code; or
- Other approved underlayments.

C. Where roof slopes are 4/12 and greater, underlayment shall be one layer ASTM D 226, Type II (No. 30 felt), and along eaves, 24 inches, install two layers shingle fashion solidly cemented with approved material or an approved, self-adhering underlayment.

International Building Code (IBC)

The information regarding underlayments is presented in Chapter 1507 of the 2000 International Building Code, and is as follows:

Clay and Concrete Tile:

- A. Unless otherwise noted, required underlayment shall conform to ASTM D 226, Type II; ASTM D 2626; or ASTM D 249 Type I mineral-surfaced roll roofing.
- B. The installation requirements are as follows: Where roof slopes fall between 2-1/2:12 and under 4:12, underlayment shall be two layers installed in shingle fashion overlapping 19 inches and fastened sufficiently to hold in place. Where roof slopes are greater than 4:12, underlayment shall be one layer installed in shingle fashion, lapping two inches, and fastened sufficiently to hold in place.

Asphalt Shingles:

- A. Unless otherwise noted, required underlayment shall conform to ASTM D 226, Type I, or ASTM D 4869, Type I. Self-adhering, polymer-modified bitumen sheet to be used as an underlayment shall comply with ASTM D 1970.
- B. The installation requirements are as follows: Where roof slopes fall between 2:12 and 4:12, underlayment shall be two layers installed in shingle fashion overlapping 19 inches and fastened sufficiently to hold in place. Where roof slopes are 4:12 or greater, the underlayment shall be one layer installed in shingle fashion, lapping two inches, and fastened sufficiently to hold in place.
- C. In areas where the average daily temperature in January is 25 degrees Fahrenheit or less or where there is a possibility of ice forming along the eaves causing a back-up of water, an ice shield that consists of at least two layers of underlayment



RCI, Inc.
800-828-1902
www.rci-online.org

cemented together, or a self-adhering, polymer-modified bitumen sheet shall be used in lieu of normal underlayment and extend from the eave's edge to a point at least 24 inches inside the inside of the exterior wall line of the building.

Metal Roof Shingles, Wood Shakes, Wood Shingles, and Slate Shingles:

- A. Underlayment for metal roof shingles, wood shakes, and wood shingles shall conform with ASTM D226, Type I.
- B. Underlayment for slate shingles shall comply with ASTM D 226, Type II.
- C. In areas where the average daily temperature in January is 25 degrees Fahrenheit (-4 degrees Celsius) or less or where there is a possibility of ice forming along the eaves causing a backup of water, an ice barrier that consists of at least two layers of underlayment cemented together or of a self-adhering polymer modified bitumen sheet, shall be used in lieu of normal underlayment and extend from the eave's edge to a point of at least 24 inches (610mm) inside the exterior wall line of the building.
- D. Interlayment for wood shakes shall comply with ASTM D 226, Type I.

International Conference of Building Officials Evaluation Services, Inc. (ICBO ES)

The International Conference of Building Officials Evaluation Services, Inc. (ICBO ES) has developed criteria for various underlayment products based upon performance features of the Uniform Building Code, International Building Code, and the International Residential Code. This information is presented in Acceptance Criteria reports with an "AC" and numerical designation. The purpose of this criteria is to establish requirements for recognition of roof underlayments in ICC-ES Legacy reports under UBC, IBC, and IRC. The criteria are limited to membrane materials used as roofing underlayment – either self-adhering or mechanically attached and installed over solid sheathing.

Each of these Acceptance Criteria reports is intended to provide criteria for membrane materials that are alternatives to Type 15 and Type 30 felts that are specified in Chapter 15 of UBC and ASTM D 226, Type I and II that are specified in Chapter

15 of the IBC, and Chapter 9 of the IRC. The criteria reports that have been published are as follows:

AC 48, "Acceptance Criteria for Roof Underlayment for Use in Severe Climate Areas"

- This criteria report outlines information for underlayments installed over solid sheathing on areas subject to wind-driven snow or ice buildup and in areas where the average daily temperature in January is 25 degrees F or has a possibility of ice forming along the eaves causing backup of water. The various performance criteria included in this report include the fol-

lowing: tensile strength, water vapor transmission, pliability, water ponding, peel adhesion, elongation, accelerated aging, and UV exposure. This report was effective on February 1, 2000.

AC 160, "Acceptance Criteria for Nonasphaltic Fiberglass Based Roof Underlayment"

- This report outlines criteria for proprietary sheet materials consisting of fiberglass mat that is factory impregnated and coated with polymers. The various performance criteria included are as follows: water vapor transmission, pliability, liquid water transmission, average



RCI, Inc.
800-828-1902
www.rci-online.org

breaking strength, average tear strength, durability, loss of ignition, and fire resistance properties. This report was effective February 1, 2000.

AC 165, "Acceptance Criteria for Asphalt Coated Glass Fiber Mat Roof Underlayment" – This report outlines criteria for asphalt-coated, fiberglass-reinforced products. It provides both prescriptive criteria [i.e., roll size, moisture content, percentages of components (surfacing/stabilizers, asphalt, ash, desaturated mat), etc.] and various performance criteria such as: average break strength, pliability, liquid water transmission, and loss on heating. This report was effective August 1, 2000.

AC 188, "Interim Criteria for Roof Underlayments" – The purpose of these acceptance criteria is to establish requirements for recognition of roof underlayments listed in ICC-ES legacy reports under the Uniform Building Code, International Building Code, and the International Residential Code. The criteria is limited to membrane materials used as roofing underlayment – either self-adhering or mechanically attached, and installed over solid sheathing. This report outlines the following performance criteria: UV exposure, tensile strength, adhesion in peel, liquid water transmission, and cycling and elongation. This report was effective on March 1, 2003.

AC 207, "Acceptance Criteria for Polypropylene Roof Underlayments" – This report outlines criteria for spun bond polypropylene materials used in mechani-

cally attached roofing underlayments installed over solid sheathing. The various performance criteria included in this report are as follows: water vapor transmission, pliability, liquid water transmission, rupture resistance, tear resistance, accelerated aging, UV exposure, and Class A intermittent flame and burning brand fire resistance when installed in conjunction with asphalt shingles. This report was effective October 1, 2002.

The performance criteria and minimum standards established by these reports are as follows:

- **Accelerated Aging (AC 48)** – No visible damage.
- **Pliability (ASTM D 226)** – No cracking over 90-degree bend/half-inch radius.
- **UV Exposure (AC 48)** – No visible damage.
- **Tensile Strength (AC 48)** –
 - ASTM D 828: 20 lbf/inch width (min.)

* ASTM D 1682: 75 lbf (min.)

* ASTM D 1970: 25 lbf/inch width (min.)

- **Adhesion in Peel (AC 48)** – 75% of control sample.
- **Cycling and Elongation** – No cracking or bond failure.

Summary

There is a wide variety of minimum guidelines offered by a multitude of industry associations for various products and compositions for underlayments to be installed below the primary roof covering for steep-sloped roof applications. Each product being considered for use on a project should be evaluated based on performance criteria, application and project requirements, product availability, warranty requirements, material compatibility, budgetary considerations, and code/regulatory issues to determine appropriateness for the respective project. 

Karl A. Schaack, RRC, PE

Karl A. Schaack, RRC, PE, is president of Price Consulting, Inc., a roofing and waterproofing consulting firm in Houston, Texas. Mr. Schaack has a bachelor's degree in civil engineering from Clemson University. He is a registered professional engineer in Texas, South Carolina, and North Carolina. Karl is a member of RCI, the Roofing Contractors Association of Texas, and the Gulf Coast Chapter of RCI. He is an RRC and a former director of RCI's original Region IV.

