

# NFPA 285-2006:

## APPROVAL FOR WALL ASSEMBLIES USING FOAM PLASTIC INSULATION

BY JEFF HANSBRO

### NFPA 285-2006: AN OVERVIEW

This white paper briefly describes the National Fire Protection Agency (NFPA) 285-2006 standard fire test, which has attracted a great deal of attention in recent years. It is important to note, however, that some version of this critical test standard has been codified since the late 1980s.

The assembly test UBC 17-6 and other requirements for use on noncombustible

walls were inserted into the 1988 edition of the International Conference of Building Officials (ICBO) Uniform Building Code (UBC). The UBC 17-6 was developed using tests of Insulated Metal Panel systems (IMPs) and an Exterior Insulation and Finishing System (EIFS). Also, at approximately that time, the other model building codes (the Southern Building Code Congress International code and the Building Officials and Code Administrators International, Inc. code) included language requiring testing of exterior wall assemblies containing foam plastic for vertical flame spread. The large-scale UBC 17-6 was renamed UBC

26-4, and within a few years, the intermediate-scale UBC 26-9 was developed and referenced in the UBC.

When the International Building Code (IBC) was promulgated in 2000, NFPA 285 was cited since it was an ANSI-approved version of UBC 26-9. At the time, UBC 26-4 was also included to allow for manufacturers with tested and approved wall assemblies per UBC 26-4 to

continue and update their approvals to the new NFPA 285 standard. UBC 26-4 was subsequently removed from the 2003 IBC, leaving NFPA 285 as the require-

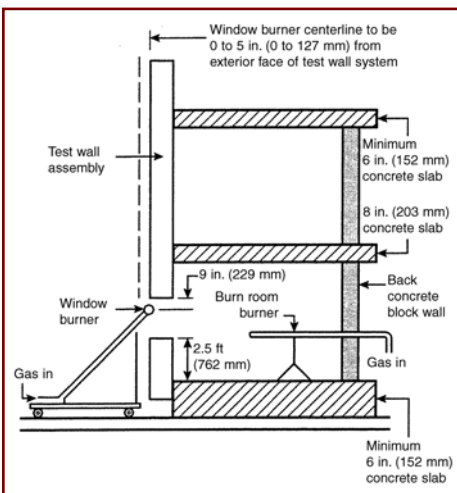

Figure 1 – Side view of burner placement in first-story test room (not to scale).

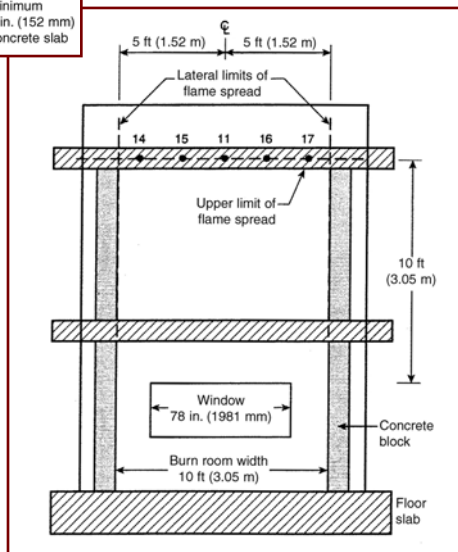

Figure 2 – Limits of flame propagation (not to scale).



Figure 3 – NFPA 285 assembly test 285 with brick veneer wall and foam plastic insulation.



Figure 4 – NFPA 285 assembly test with NFPA 285-approved metal composite metal (MCM) veneer and ASTM C1289 Type 1 Class 2 fiberglass-reinforced ISO insulation.

ment per Section 2603.5.5 of the IBC (IBC 2003-2009).

NFPA 285 testing provides a method of determining the flammability characteristics of exterior, non-load-bearing wall assemblies/panels that contain foam plastic insulation. The test method described is intended to evaluate the inclusion of combustible components within wall assemblies/panels that are required to be of noncombustible construction. It is intended to simulate the multistory flammability fire performance of entire exterior wall assemblies.

An international nonprofit membership organization, NFPA is the world's leading advocate of fire prevention and an authoritative source on public safety. The NFPA's mission is to reduce the worldwide burden of fire and other hazards on the quality of life by developing and advocating consensus codes and standards, research, training, and education.

#### NFPA 285 APPROVAL REQUIREMENTS PER IBC

As stated, Section 2603.5.5 of the 2000, 2003, 2006, and 2009 editions of the IBC requires that exterior wall systems on buildings of any height that incorporate foam plastic insulation of Type I, II, III, or IV classification must meet the requirements of NFPA 285-2006, Standard Fire Test Method for Evaluation of Fire Propagation Characteristics of Exterior Non-Load-Bearing Wall Assemblies Containing Combustible Components Using the Intermediate-Scale, Multistory Apparatus.



Figure 5 – NFPA 285 assembly test with an NFPA 285-approved MCM veneer and ASTM C1289 Type 1 Class 2 fiberglass-reinforced ISO insulation (post-fire view).

Foam plastics can be open-cell and closed-cell SPF insulating foams, or rigid board stock insulations of EPS, XPS, and ISO chemistries. Type IV and Type X extruded polystyrene and polyisocyanurate insulation products classified as foam plastic insulation for exterior applications must pass NFPA 285-2006 testing.

It is important to understand that the NFPA 285-2006 standard fire test is an assembly test, not a component test. The details of the test assembly and application materials should be strictly followed in practice. According to Chapter 26 of the

IBC, Section 2603.5.5:

The wall assembly shall be tested in accordance with and comply with the acceptance criteria of NFPA 285. Exception: One-story buildings complying with Section 2603.1.4.

#### NFPA 285-2006 TESTED SYSTEMS USING FOAM PLASTIC INSULATION

##### Requirements

The NFPA 285-2006 testing apparatus is a two-story wall assembly that includes a framed window opening on the first floor.



RCI, Inc.  
800-828-1902  
[www.rci-online.org](http://www.rci-online.org)

Figure 6 – XPS foam insulation in steel cavity wall. Mineral wool fire safing (minimum of 1 in thick) is required in the header of all openings.

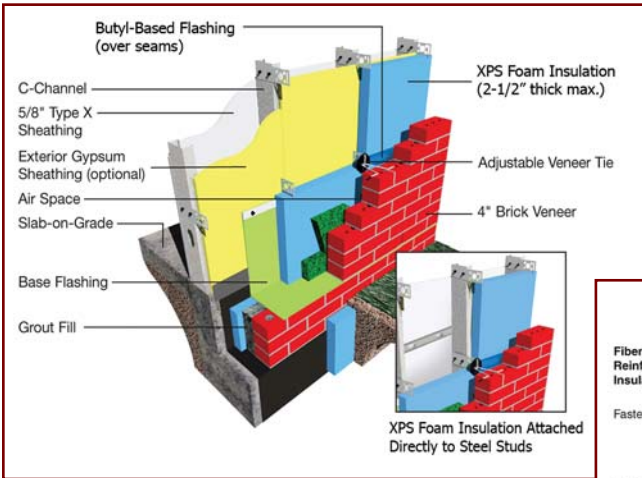

The pass/fail criteria are that flame propagation must not occur either vertically or laterally beyond an acceptable distance from the area of flame plume impingement on or within the wall assembly. Thermocouples are placed throughout the wall, and the defined temperature limits cannot be exceeded; otherwise, the test is considered a failure.

Figure 8 – Steel stud assembly with brick veneer (Type 1, Class 2 ISO foam insulation with integral drainage plane and air barrier).

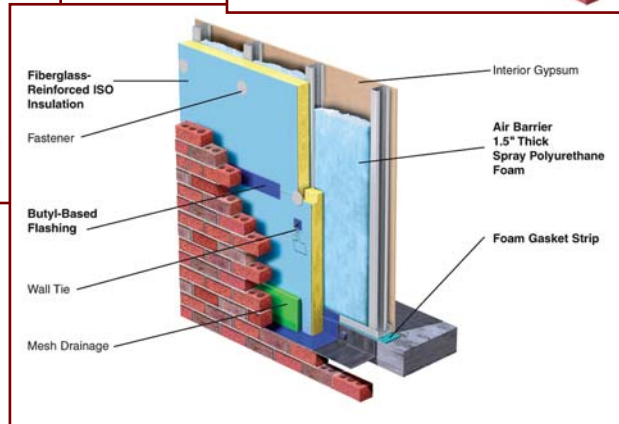
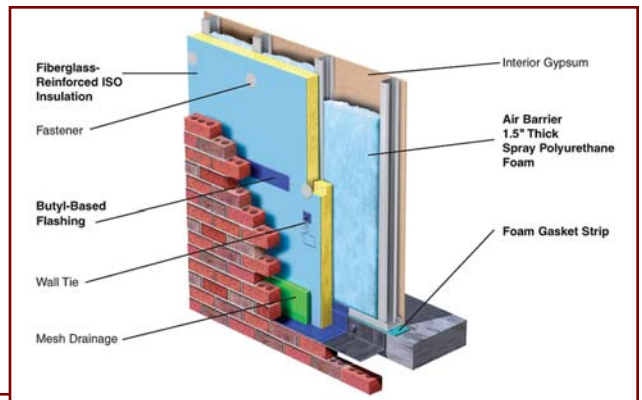

Figure 7 (above) – XPS foam insulation in block-backed cavity wall. Mineral wool fire safing (minimum of 1 in thick) is required in the header of all openings.



Diagrams of the NFPA test assembly are shown in Figures 1 and 2. Views of the test itself are shown in Figures 3, 4, and 5. Figures 6, 7, 8, 9, and 10 show some of the approved wall assemblies that include foam plastic insulation. The manufacturer of foam plastic insulation or veneer can answer technical questions related to specific assemblies or veneer types not shown here.

The NFPA 285-2006 standard fire test is an assembly test, not a component test. The details of the test assembly and application materials should be strictly followed in practice.

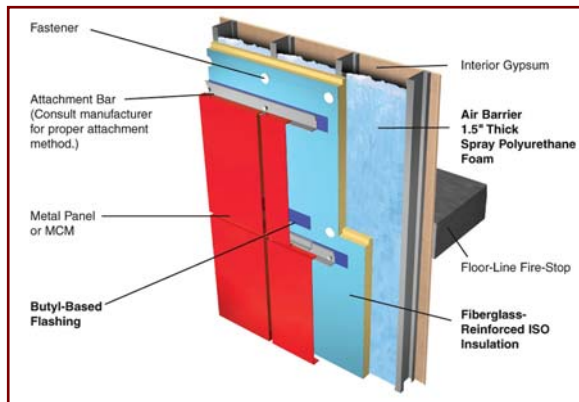

Figure 9 – Steel stud assembly with metal panel or an NFPA 285-approved MCM veneer (Type 1, Class 2 ISO foam insulation with integral drainage plane and air barrier).

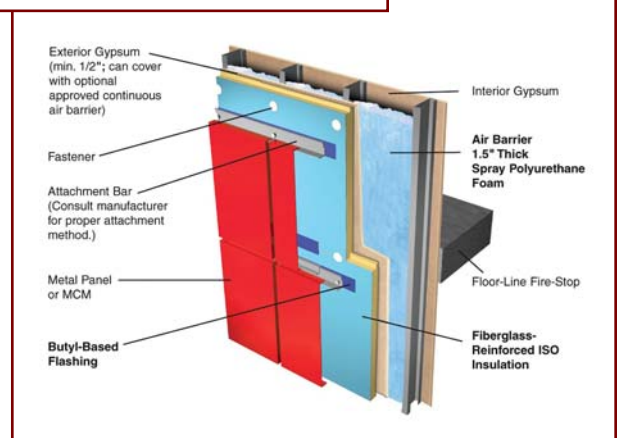

Figure 10 – Steel-stud assembly with exterior gypsum and metal panel or an NFPA 285-approved MCM veneer (Type 1, Class 2 ISO foam insulation with integral drainage plane and air barrier).

Jeff Hansbro



Jeff Hansbro is the commercial construction applications technology leader in North America for Dow Building Solutions. He is responsible for defining sustainable products and systems for building enclosures as measured by their resistance to heat, air, and moisture properties in a specified climate. His previous positions at Dow include senior technical service development specialist and senior product development engineer. Prior to his employment at Dow, Hansbro worked at Celotex Corporation and BASF in their urethanes research divisions. Hansbro graduated from Wayne State University with a B.S. in chemical engineering and is presently pursuing a M.S. in engineering and marketing at Northwestern University. He is certified as a Six Sigma MAIC black belt.